

## Sentinel Eliminator Vortex<sup>®</sup>250

Ultra-compact filter for powerful magnetic filtration of system debris

Circulating debris in central heating systems can cause wear and premature failure of pumps, valves and heat exchangers. Sentinel Eliminator Vortex250, fitted under the boiler, will protect the system against all types of debris and is ideal for installations where space is highly restricted.

- **Ultra-compact filter**  
Ideal for space constrained and cupboard fit installs.
- **Highest quality materials and construction**  
Reassurance of a robust product with low intervention costs thanks to dual seals, automotive grade GRP body and a forged brass T-piece with integrated isolation valve.
- **Thorough mess-free clean in seconds without tools**  
Flush for speedy service and reduced time on site or strip down demonstration to show homeowner.
- **9000 Gauss magnet with 180 ml collection capacity**  
Maximises first pass and continuous debris collection and ensures retention of debris.

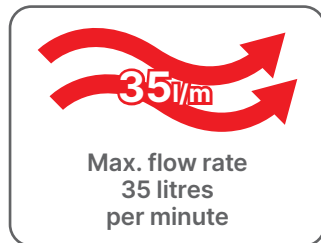
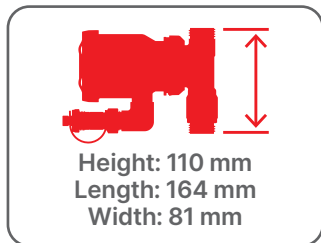
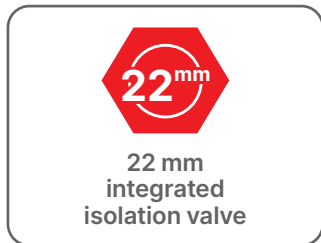

**The Sentinel System**  
Lifetime protection for heating, cooling and hot water systems using the best practice process of...

**CLEAN**  
WITH  
APPROPRIATE  
CLEANER

**PROTECT**  
WITH  
X100  
INHIBITOR

**MAINTAIN**  
WITH  
X100  
TEST KIT

## Description

Sentinel Eliminator Vortex<sup>®</sup>250 system filter removes all types of debris commonly associated with wet central heating systems, affording boiler protection and helping to maintain optimum system operation and efficiency.

## Operation

Sentinel Eliminator Vortex250 is designed to fit directly under the boiler in restricted spaces. The powerful neodymium-ironboron magnets enhance magnetite capture and retention. The collected debris can simply be flushed away by removing the magnet from its sleeve and opening the flush valve at the bottom of the unit.

## Additional Features

**Isolation:** Integrated isolation valve in the brass T-piece

**Filter chamber capacity:** 180 ml

**Compact design:** Minimal height for easy installation into boiler cupboards and tight spaces

**Tamper proof:** Drain valve with safety mechanism

**Dosing:** Compatible and Sentinel Rapid-Dose<sup>®</sup> 300ml

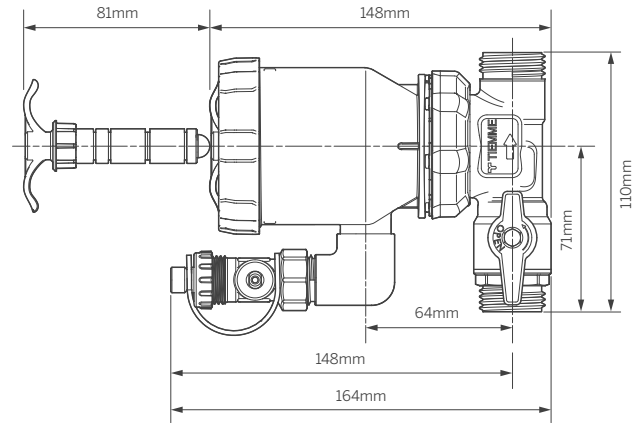

## Technical Specifications

Maximum temperature: 100°C

Maximum operating pressure: 3 bar

Maximum flow rate: 35 litres/min

Mounting: Horizontally mounted

Connectors: 22 mm compression (fittings included)

Weight (boxed): 1.1 kg

## Pressure Loss Chart - Eliminator Vortex250

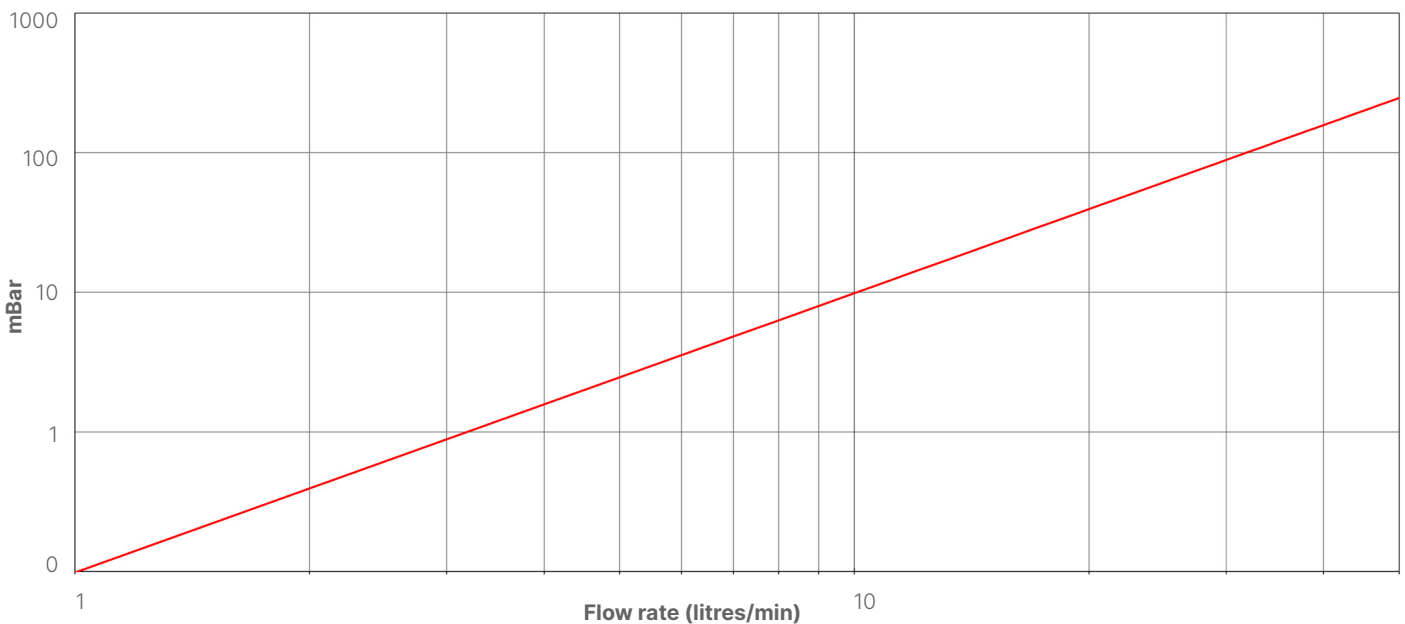

The use of Sentinel water treatment is endorsed by the industry's major international manufacturing companies\*



### Sentinel Performance Solutions Ltd.

7650 Daresbury Park, Warrington, Cheshire, WA4 4BS, United Kingdom. Tel: +44 (0) 1928 704 330

Sentinel is a trade mark owned by Sentinel Performance Solutions Ltd.

www.sentinelprotects.com

